

TOPKEY
Excellence in Composites

股票代號-4536

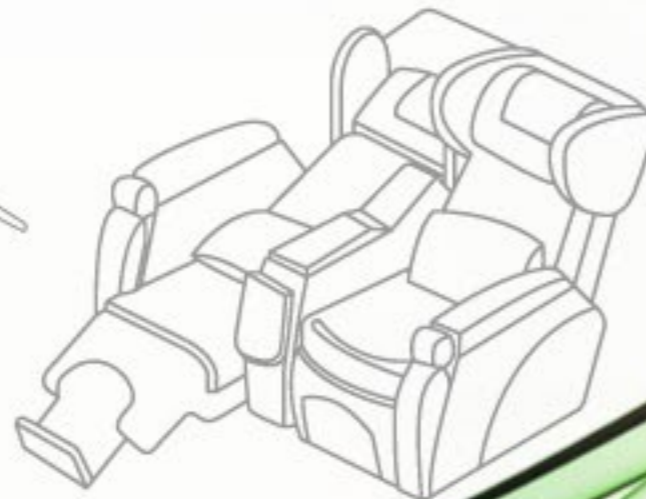

Topkey in your Life

- 拓凱集團簡介
- 核心技術
- 拓凱事業群
- 企業社會責任



拓凱實業股份有限公司

董事長：沈文振

總經理：朱東鎮

員工數：248人

設立日期：民國69年7月11日 <34年>

資本額：新台幣9.082億元

公司及工廠地址：台中市工業區20路18號

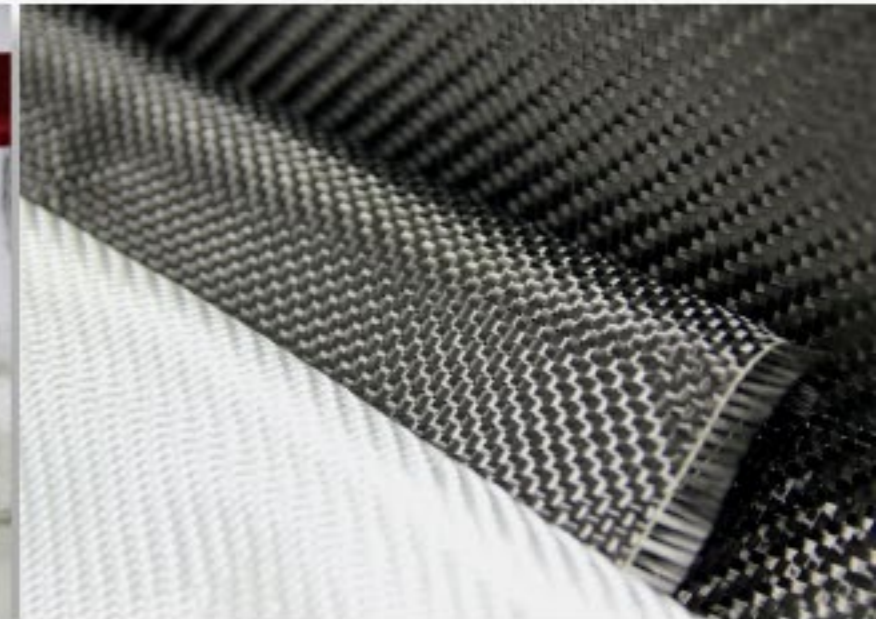

2014 拓凱集團架構圖

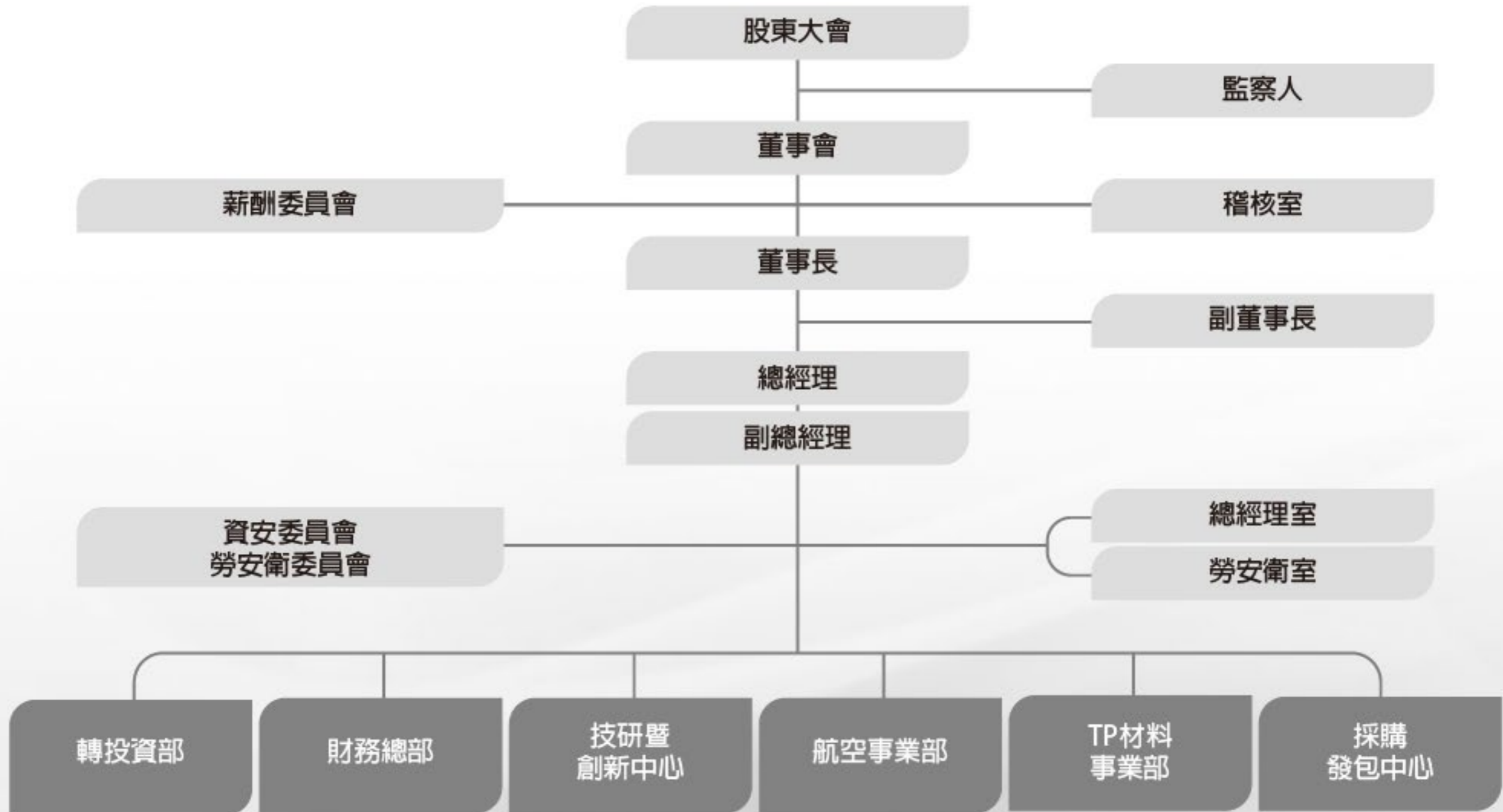

拓凱集團規模

2014 員工人數

拓凱實業股份有限公司	248
廈門新凱複材科技有限公司 杏林園區	1,803
廈門新凱複材科技有限公司 后溪園區	3,126
Composite Solutions	82
廈門宇詮複材科技有限公司	798
廈門新鴻洲精密科技有限公司	2,362
廈門元富彩色貼紙有限公司	156

員工總人數 : 8,575人

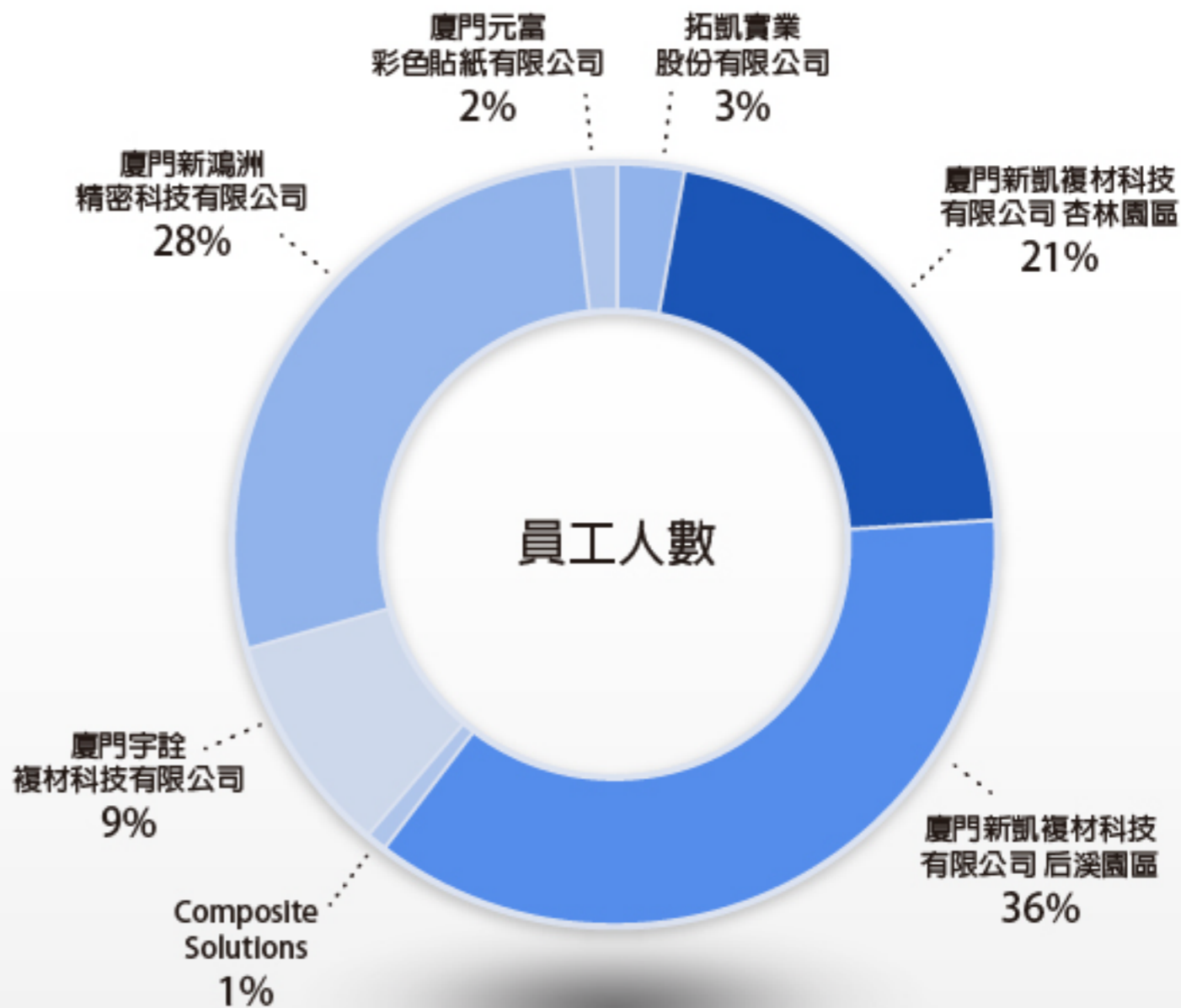

拓凱集團規模

2014 總樓地板面積 (m²)

拓凱實業股份有限公司	14,877
廈門新凱複材科技有限公司 杏林園區	58,930
廈門新凱複材科技有限公司 后溪園區	97,341
Composite Solutions	6,417
廈門宇詮複材科技有限公司	26,260
廈門新鴻洲精密科技有限公司	27,608
廈門元富彩色貼紙有限公司	3,700

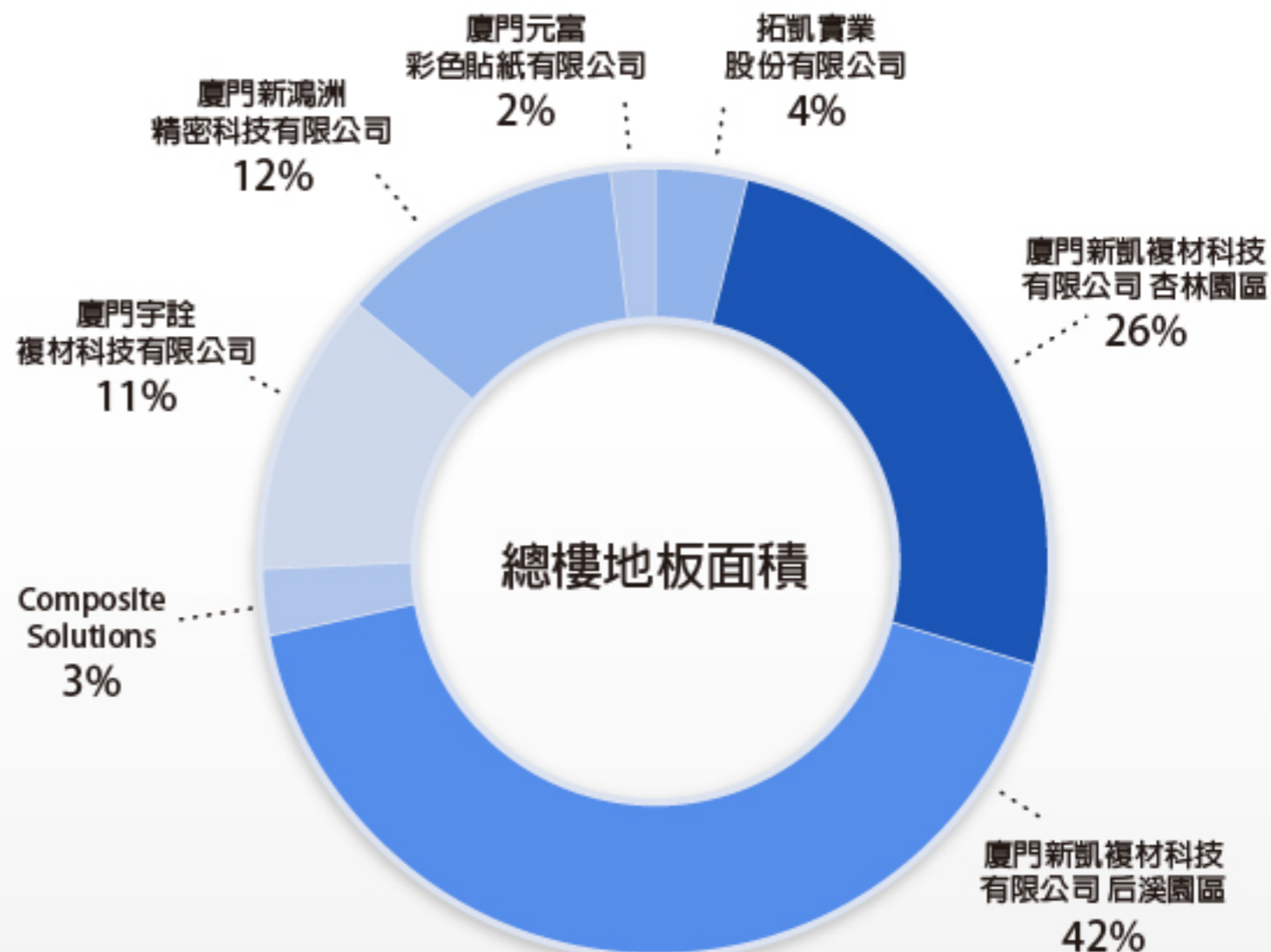

總樓地板面積 : 235,133 m²

拓凱集團營運據點



1980

台灣 - 台中

拓凱實業股份有限公司



1988

中國 - 廈門

新凱複材科技有限公司 杏林園區



1995

美國 - 西雅圖

Composite Solutions



1999

中國 - 廈門

宇詮複材科技有限公司



2000

中國 - 廈門

新鴻洲精密科技有限公司



2004

中國 - 廈門

元富彩色貼紙有限公司



2007

中國 - 廈門

新凱複材科技有限公司 后溪園區

拓凱大事記

開創及穩定期

1980 ~ 1993

產業轉型期

1994 ~ 2000

產業升級創新期

2001 ~ 2014



球拍



預浸料



腳踏車



安全帽



航空

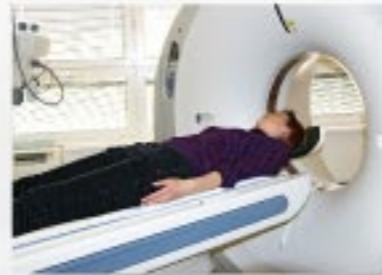

醫療



航空內裝



電子3C產品



汽車配件



拓凱大事記

1980	1991	1995	2001	2014
生產碳纖維網球拍	生產碳纖維自行車架，碳纖維複材安全帽	併購美國西雅圖CSC 航太生產基地	生產碳纖維飛機內裝與醫療相關產品	持續開發航空結構件及工業產品相關複合材料製品
				

全球合作夥伴

球拍產業



航太產業



3C產業



自行車產業



供應商



安全產業



醫療產業



主要產品與產業多元化

以複合材料為中心，五大產業在規模與技術上，都是世界領先。



**GLOBAL
No.1**



經營理念

創新材料科技的運用，提升健康、
休閒、幸福的生活，促進社會與環境的和諧。



- 拓凱集團簡介
- 核心技術
- 拓凱事業群
- 企業社會責任

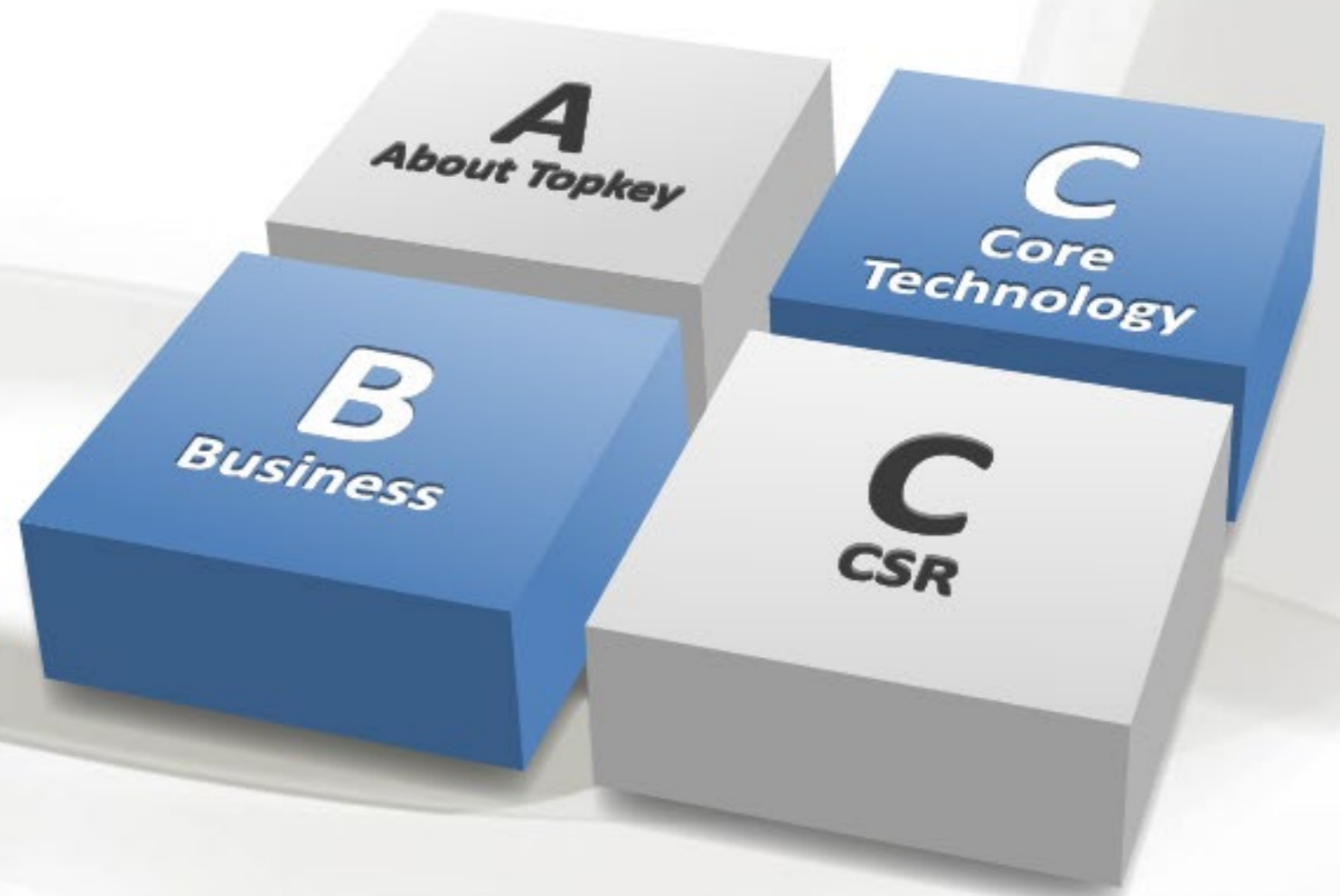

拓凱集團-核心競爭力



全方位客戶服務



碳纖維材料優越特性

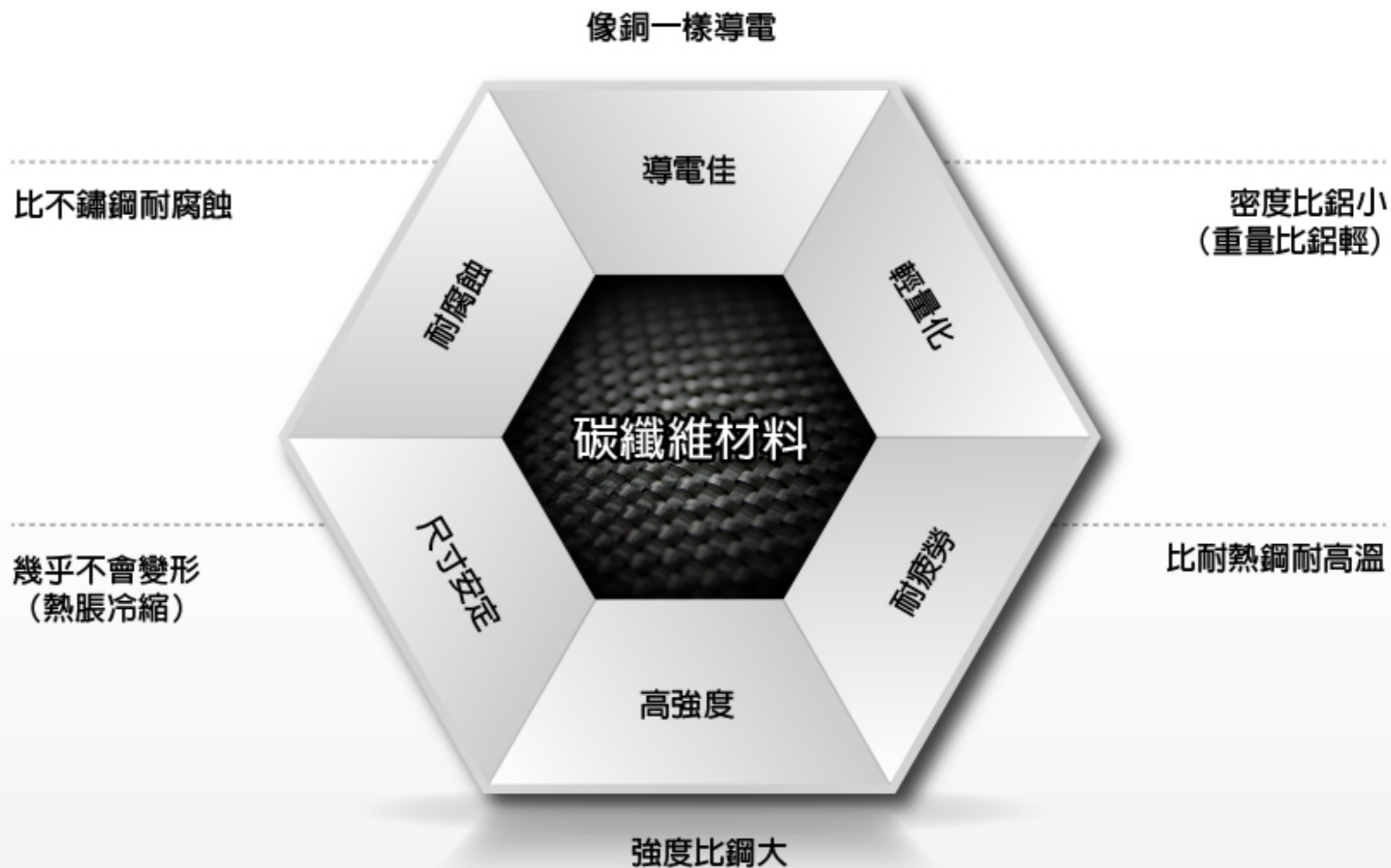

優越的 電學性能 + 熱學性能 + 力學性能

目前幾乎沒有其他材料同時擁有這麼多的優異性能

全方位客戶服務

- 樹脂基材(TS)
- 纖維基材
- 樹脂基材(TP)

複材基材



- TS 織板
- TP 織板
- 織布

預浸材

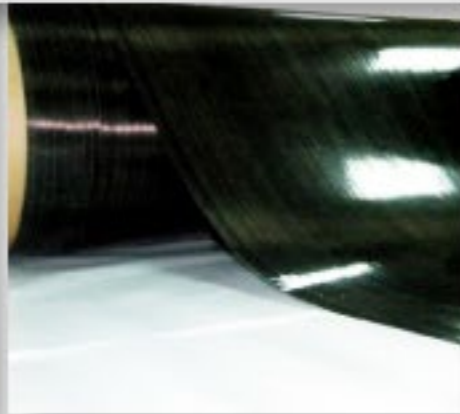

- 平板
- 管件
- 3D 曲面
- 單向積層

積層



- 抽真空成型
- 真空壓力釜成型
- 氣袋成型
- 沖壓成型
- 纏繞成形
- 樹脂模塑成型
- 點加熱成型
- 熱壓成型

生產製程



- 球拍
- 腳踏車
- 安全
- 醫療
- 航太
- 熱塑型

產品應用



產品流程

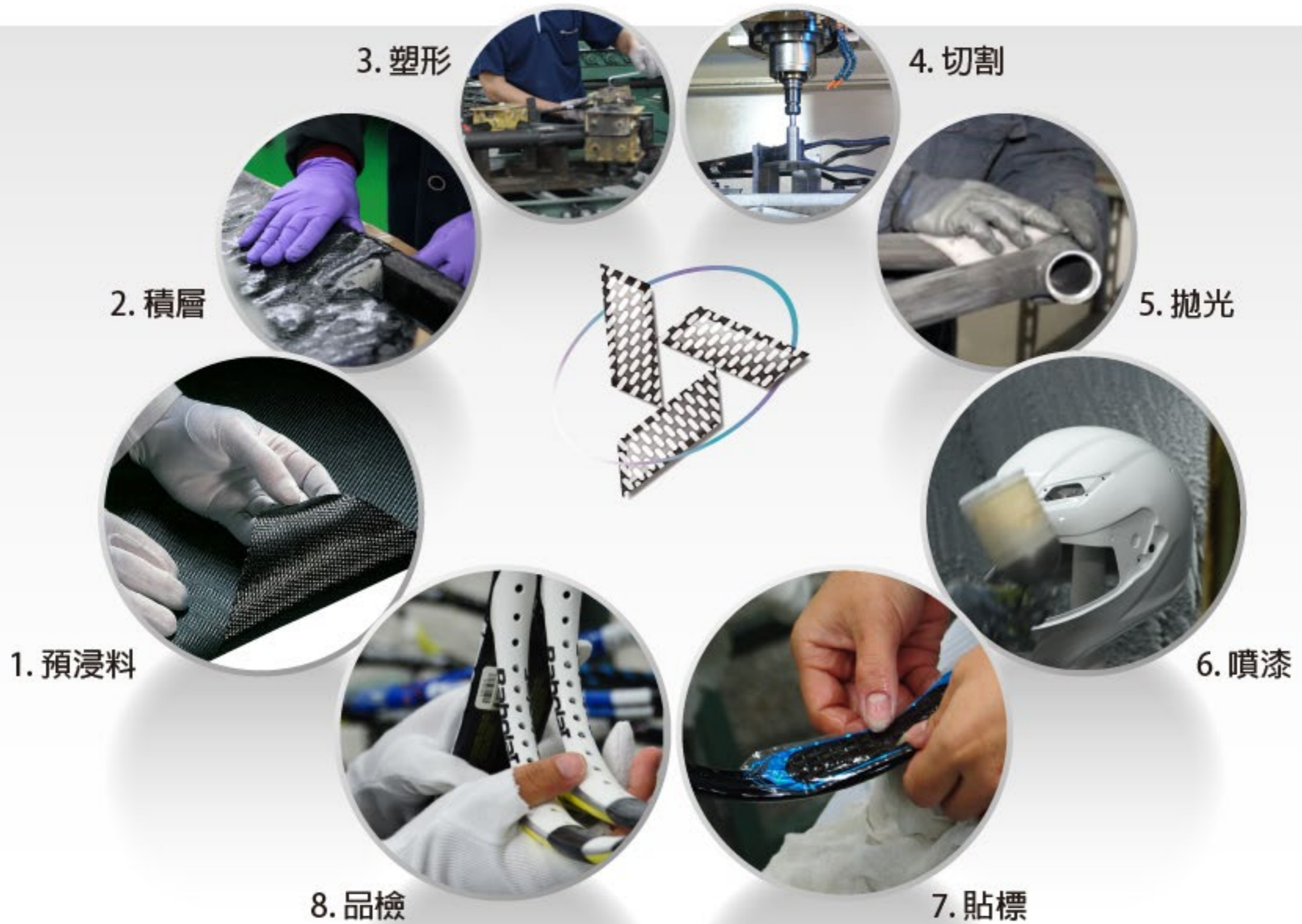

技術研發-材料微觀分析



萬能材料試驗機

- Mechanical property of Composite Bending, Tension, Compression
- Temperature range -40°C~250°C



動態機械分析儀

- Glass transition temperature
- Degree of cure
- Modulus/Viscosity
- G' , G''



微差熱掃描卡計

- Glass transition temperature
- Reaction Kinetic
- Rate of cure
- Melting point
- Purity
- Thermal Stability

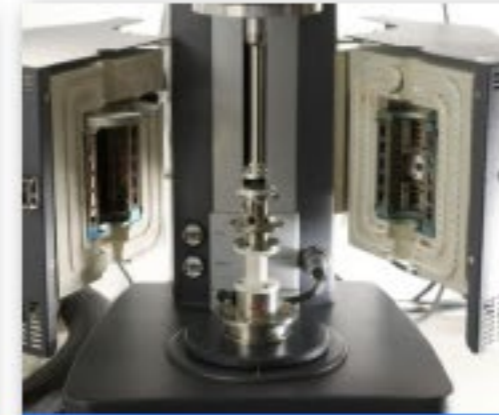

流變儀

- Relation of Viscosity vs. Temperature
- G' , G''
- Gel-point
- Temperature range : -160°C~600°C



燃點試驗箱

- Vertical burning test (FAR 25.853 a,b)
- Horizontal burning test (FAR 25.853 b2, b3)
- Flammability Test (UL-94)



掃描式電子顯微鏡

- Microcosm of composite
- Analysis of composite defect
- Magnification - 5x to 300000x



凝膠滲透色譜儀

- Molecular weight of polymer



X光能量散射儀

- Type and Content of Elements (RoHS)

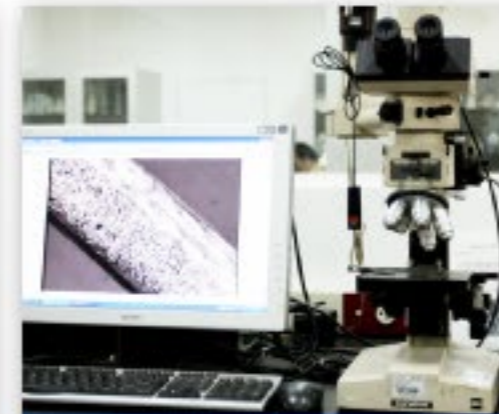

金相顯微鏡

- Magnification - 50x to 800x
- Distribution of fiber/ resin/void
- Arrangement of Lay-up



熱塑形機

- Materials Fire Properties
- Heat Release Rate (FAR 25.853)

技術研發-樹脂配方獨創

材料應用：

- ◆ 不同機能的樹脂/ 金油 / 塗料 / 底漆
 - 樹脂基材(環氧, 酚醛, 乙烯基脂, 壓克力樹脂...)
 - 底漆—環氧/ 不飽和聚酯樹脂, 塗料—聚脂塗料, 透明面漆—聚脂塗料/光固化塗料
- ◆ 預浸材：
 - UD預浸材 / 碳纖維織布 / 碳纖維織管
- ◆ 運用不同基材、FAW和纖維種類材料，含浸成單向預浸材：
 - 超過71種自行研發樹脂配方

其他所有相關於材料的研究與發展



技術研發 - 客製化製程設計



產品設計



模型製作

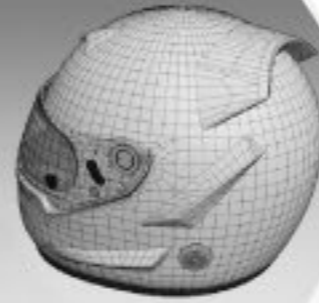

點資料掃描



細部設計檢查



設計完成



浸漬



積層



固化



修剪鑽孔



噴漆



補土精細



貼標

產品設計

產品結構設計

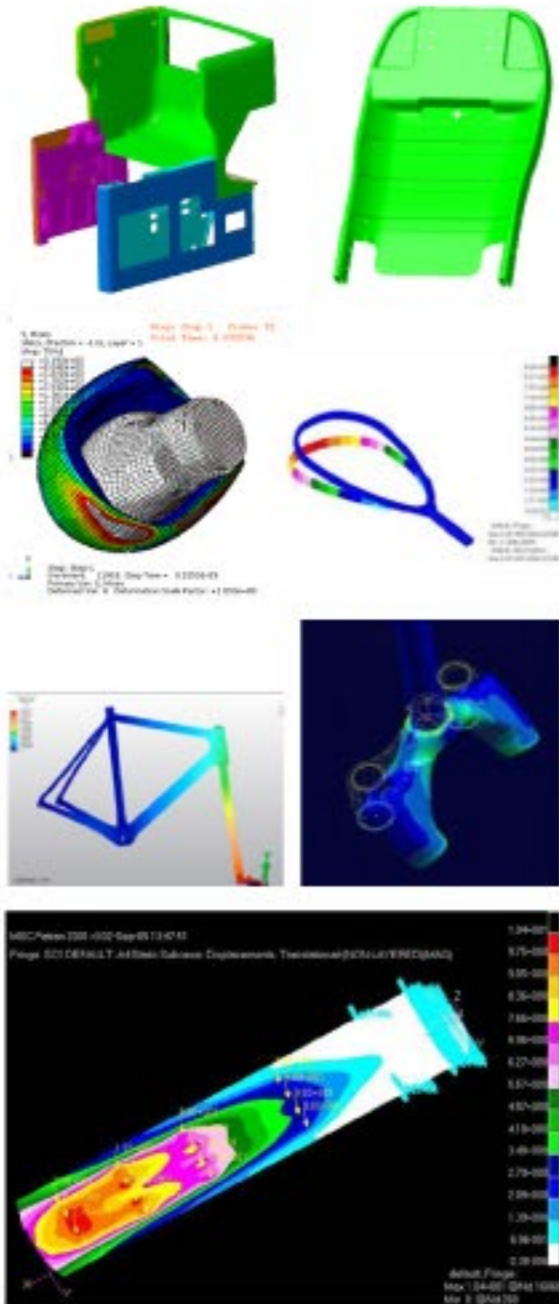

模具設計

複合模具製造

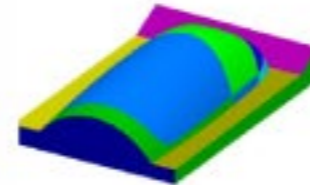

模擬創建工具面

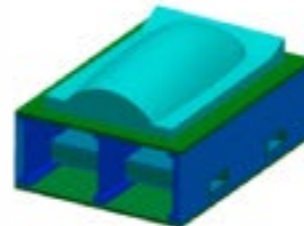

模型的切割線和開孔位置

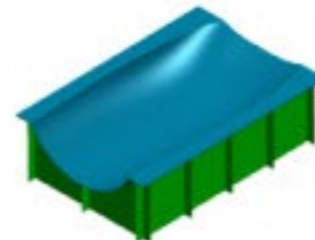

壓板的層面，並備份結構上的模具



修剪鑽孔，完成組件

組合配件設計



塗裝水標設計



品質保證 - 品質保證系統與證書



ISO9001/AS9100C/14001- KT

ISO9001/AS9100C- TK

NADCAP/AS9100B-CSC

品質保證 - 品質保證系統與證書

FST TEST : FAR 25.853 ABD 0031 & Topkey RD-C-0107

Test Method	Sub Equivalents	Flame Application Time	Material Position	Average Extinguishing Time	Average Burn Length	Average One Extinguishing Time	Flame Temperature	Temperature & Humidity of Sample
1	25.853a	30 seconds	Vertical	1.75 sec.	1.0 in.	1.1 sec.	1000° F	100% RH, 25-30°C
2	25.853a	30 seconds	Vertical	1.75 sec.	1.0 in.	1.1 sec.	1000° F	100% RH, 25-30°C

Sample No.	Test Method	Extinguishing Time (Sec)	Burn Length (Inches)	ODP Extinguishing Time (Sec)
1	2	0.8	0	NO
2	2	0.8	0	NO
3	2	0.8	0	NO
AVG	—	0.78	0	NO

Conditioning Start Date	Conditioning Start Time	Responsible party
11/19/07	3:00 pm	CTM

Test Date	Test Time	Responsible party
11/19/07	10:45 am	CTM

Temperature of Sample Prior to Test	Humidity of Sample Prior to Test	Flame Temperature
—	—	1000° F

Result: **Pass**

易燃測試

Sample No.	Sub 1	Sub 2	Sub 3	Sub 4
1	1.0	1.0	1.0	1.0
2	1.0	1.0	1.0	1.0
3	1.0	1.0	1.0	1.0
AVG	1.0	1.0	1.0	1.0

Conditioning Start Date	Conditioning Start Time	Responsible party
11/19/07	3:00 pm	CTM

Test Date	Test Time	Responsible party
11/19/07	10:45 am	CTM

Result: **Pass**

煙濃度測試

Sample No.	Sub 1	Sub 2	Sub 3	Sub 4
1	1.0	1.0	1.0	1.0
2	1.0	1.0	1.0	1.0
3	1.0	1.0	1.0	1.0
AVG	1.0	1.0	1.0	1.0

Conditioning Start Date	Conditioning Start Time	Responsible party
11/19/07	3:00 pm	CTM

Test Date	Test Time	Responsible party
11/19/07	10:45 am	CTM

Result: **Pass**

毒性測試

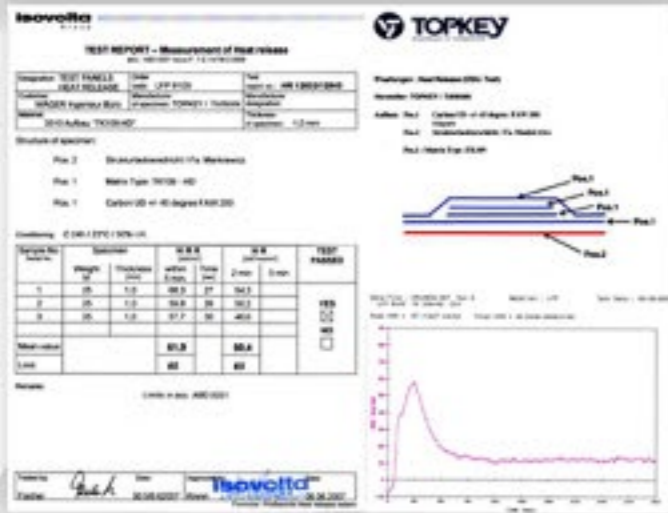

熱釋放測試



品質保證-產品測試能量

測試設備



球拍邊壓測試



車架衝擊測試



安全帽衝擊測試



疲勞測試



X射線檢測



拉伸變形測試



壓縮測試

- 拓凱集團簡介
- 核心技術
- 拓凱事業群
- 企業社會責任



球拍 - 體育用品

 **Babolat™**

Wilson.

 **DUNLOP**
SPORT

BRIDGESTONE

 **Tecnifibre®**

prince

 **adidas**

 **MIZUNO.**

- 年產能200萬支
- 世界上最大的OEM複材球拍供應商
- 50%的種子球員選擇的球拍



排名前15名的職業球員



拉斐爾·納達爾
Babolat Aero



羅傑·費德勒
Wilson 6.1



胡安·馬丁·德爾波特羅
Wilson Juice



若威爾弗里德·桑加
Babolat Aero



小威廉絲
Wilson Blade



李娜
Babolat Pure

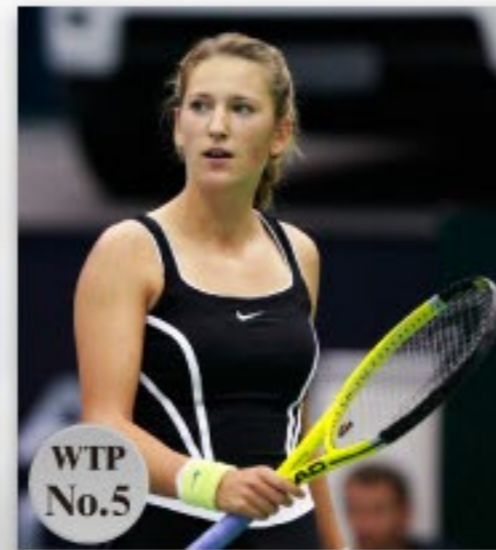

維多利亞·阿扎倫卡
Wilson Juice



薩拉·埃拉尼
Babolat Pure

自行車類產品



- 年產能30萬組
- 七組專業團隊選用的競賽自行車
- 2014年 環法及環西自行車賽冠軍

 **SPECIALIZED**

cannondale

KTM

SRAM®

SPECIALIZED



Innovation or Die



I AM SPECIALIZED

WE LOVE BIKES, RIDING THEM, MAKING THEM, GETTING OTHER PEOPLE ON THEM. FIND OUT MORE ABOUT WHO WE ARE, WHAT WE DO, AND WHY WE DO IT.

CANNONDALE Slice RS TT Team Bike

more aerodynamics, more comfortable



安全帽產品



- 年產能130萬組
- 1995年 首次設計出碳纖維複材安全帽
- 全世界最輕的安全帽（950克）
於2008年通過歐盟安全標準



醫療用產品

- 拓凱是複材斜板市場中唯一的供應商
- 生產全球頂尖的複材斜板，MRI與CT所使用的醫療床板和配件



SIEMENS

TOSHIBA



AMANN GIRRBACH



醫療用產品

PET 正子斷層掃描

CT 電腦斷層掃描

MRI 核磁共振造影

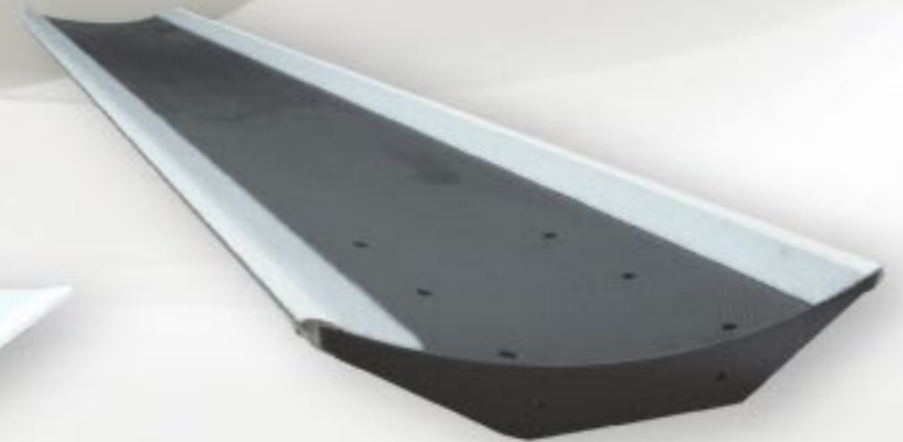
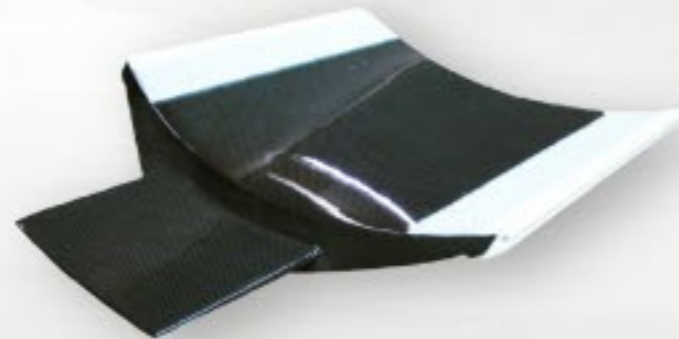

醫療用產品

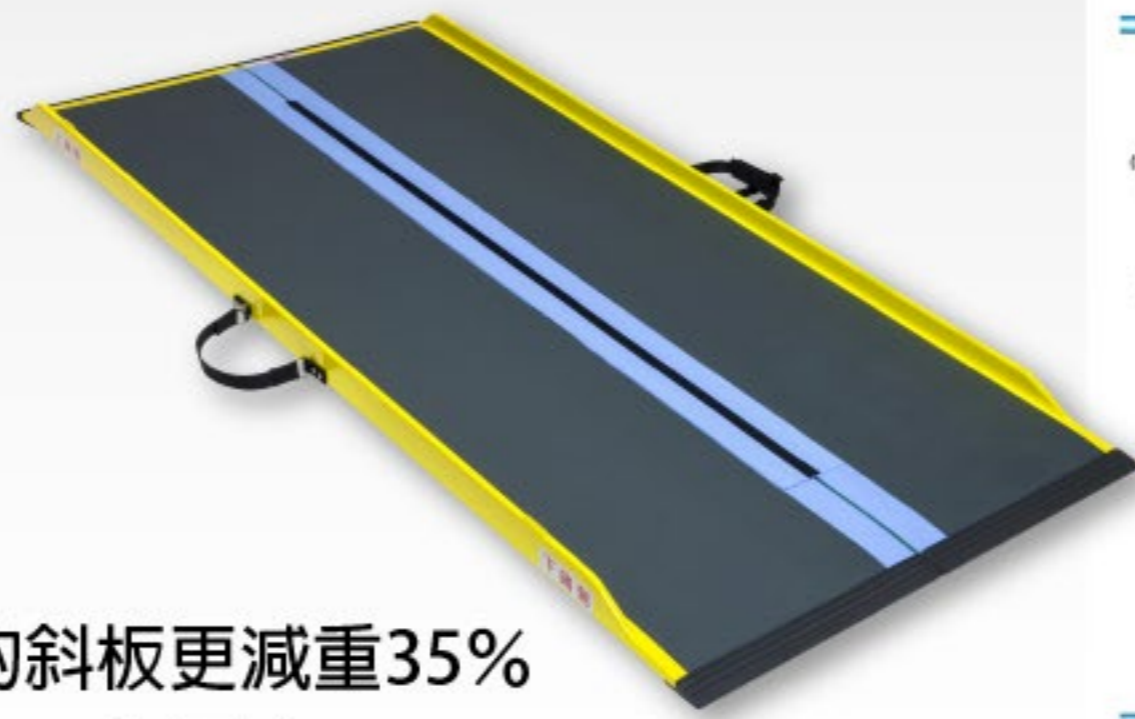
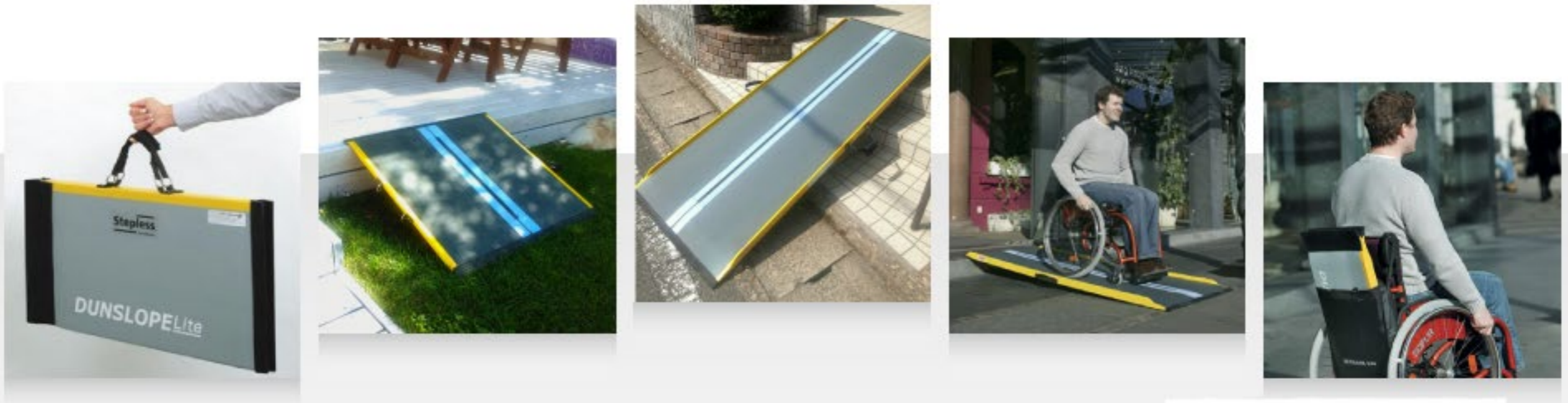

輪椅輔助斜板

複合材料的斜板比一般的斜板更減重35%

產品兼具著高強度以及輕巧等優點



其他產品

水翼輕型帆船

- 20~38公斤配件
- 40個以上的組件
- 正常風速下時速可達 8 km/hr
- 極速可達 50 km/hr



航空組件 - 客艙內飾

- 領先世界技術的複材飛機座椅製造商，經濟艙座椅椅背年產能達 20萬組以上
- 飛機椅背與內裝部件材料皆通過航太級耐燃測試



RECARO



航空組件 - 客艙內飾

商務艙與經濟艙

- 德國航空
- 柏林航空
- 聯合航空
- 杜拜航空
- 中美洲航空
- 巴西天馬航空



航空組件 - 客艙內飾

商務艙及經濟艙

- 新加坡航空
- 全日空航空
- 日本航空
- 國泰航空



航空組件 - 飛機結構部件



- MD900, MD600N, MD520N 直升機尾管結構組件
- 黑鷹直升機, S-92 傳動軸的機身
- BA-609 (Bell/Agusta) 引擎旋臂結構

航空組件 - 飛機部件



C-17 廁所 (MD)

CSC負責設計製造與測試

- 最大的乘載量設計
- 衝擊和振動測試
- 環境標準測試
- 防火測試

航空組件 - 飛機結構部件

- 直升機尾管結構組件
MD900、MD600N、MD520N
- 包括:
 - 機尾管組件
 - 水平尾翼
 - 推進器/轉錐
 - 垂直尾翼 (MD900)
- 主要結構由石墨纖維
環氧樹脂蜂巢板所組成
- 機尾管件整組運送出貨可直接組裝



航空組件 - 飛機結構部件



- 天線外殼
玻璃纖維 / 環氧樹脂

航空組件 - 飛機結構部件



- 黑鷹直升機 (Sikorsky)
拽力軸套
硫化模具 / 工裝模具



航空組件 - 飛機結構部件



- S-92 (Sikorsky)
排氣通風管
石膏模具



航空組件 - 飛機結構部件

- BA-609 (Bell/Agusta)
發動機機殼
合金模具



新鴻洲精密科技有限公司

TRULY[®]

ASUS[®]

FXLINK

NOKIA

LarView
Technologies

BlackBerry

Chicony

SHINE
SHINE.TECH

舜宇光学科技
SUNNY OPTICAL TECHNOLOGY

LITEON

ST



新鴻洲公司簡介

新鴻洲精密科技有限公司

工業模具

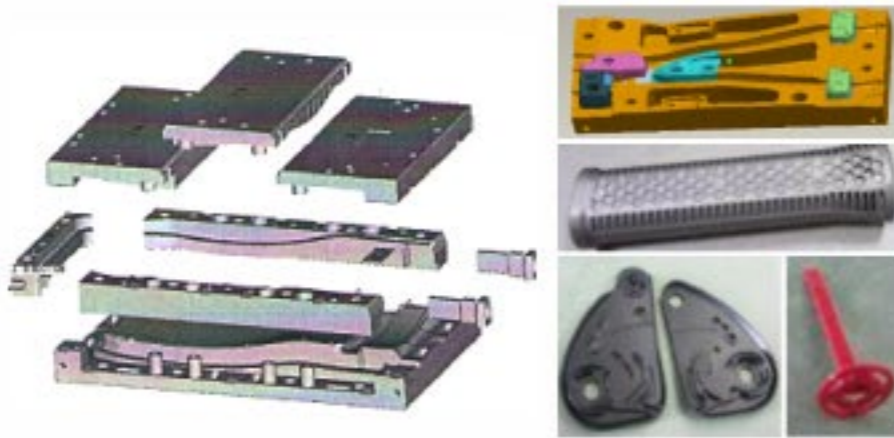

精密模具



精密射出產品

醫療器材零件

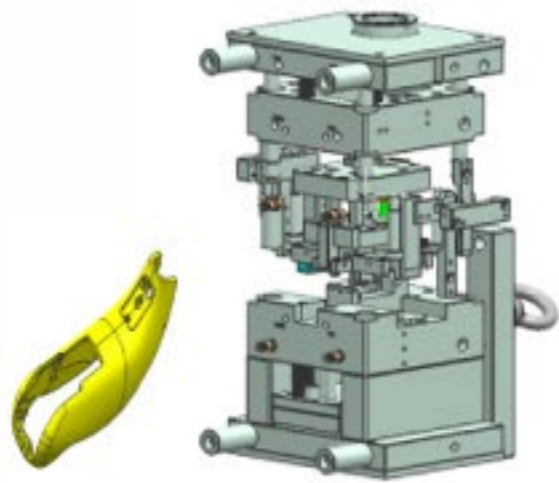

ReSound

汽車電子零件

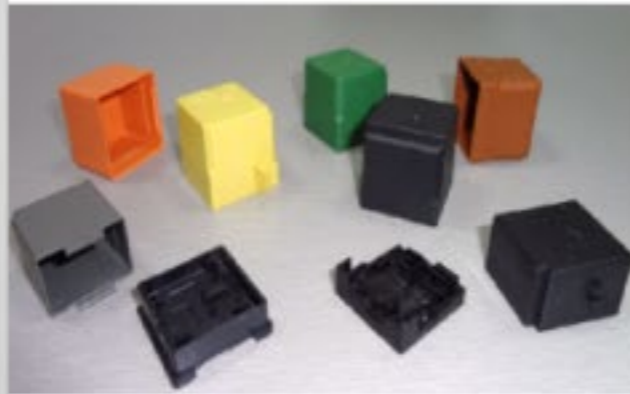
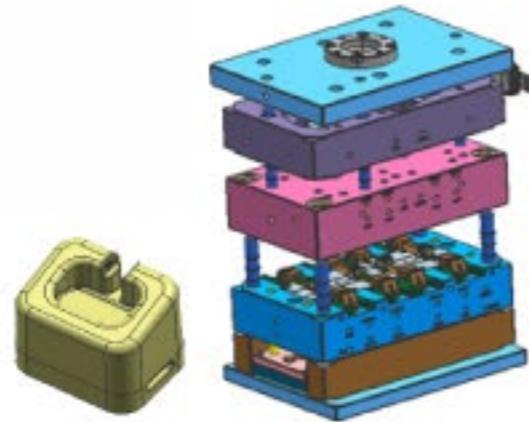

VCM 零件

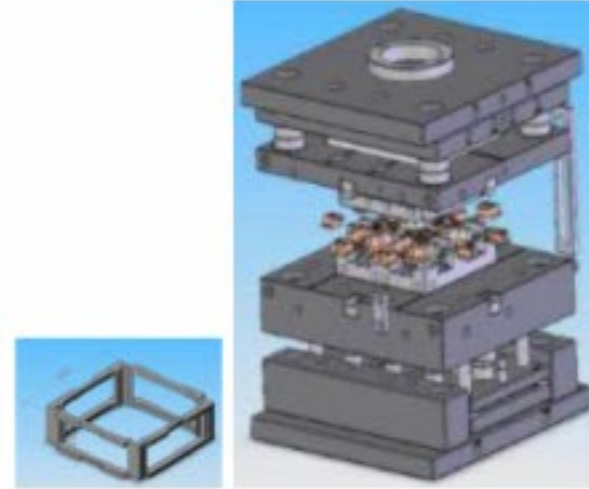

其他類

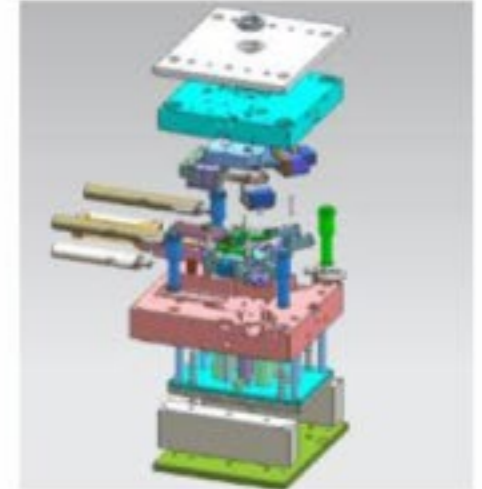

新鴻洲VCM能量

精密模具設計及
塑膠件注塑能力

VCM組裝半自動
工藝經驗



VCM組裝的設計
與製造能力

新鴻洲品質保證系統證書

ISO9001 - Year 2003



TS16949 - Year 2007



ISP14001 - Year 2007



拓凱集團 營收暨毛利率

單位：新台幣億元

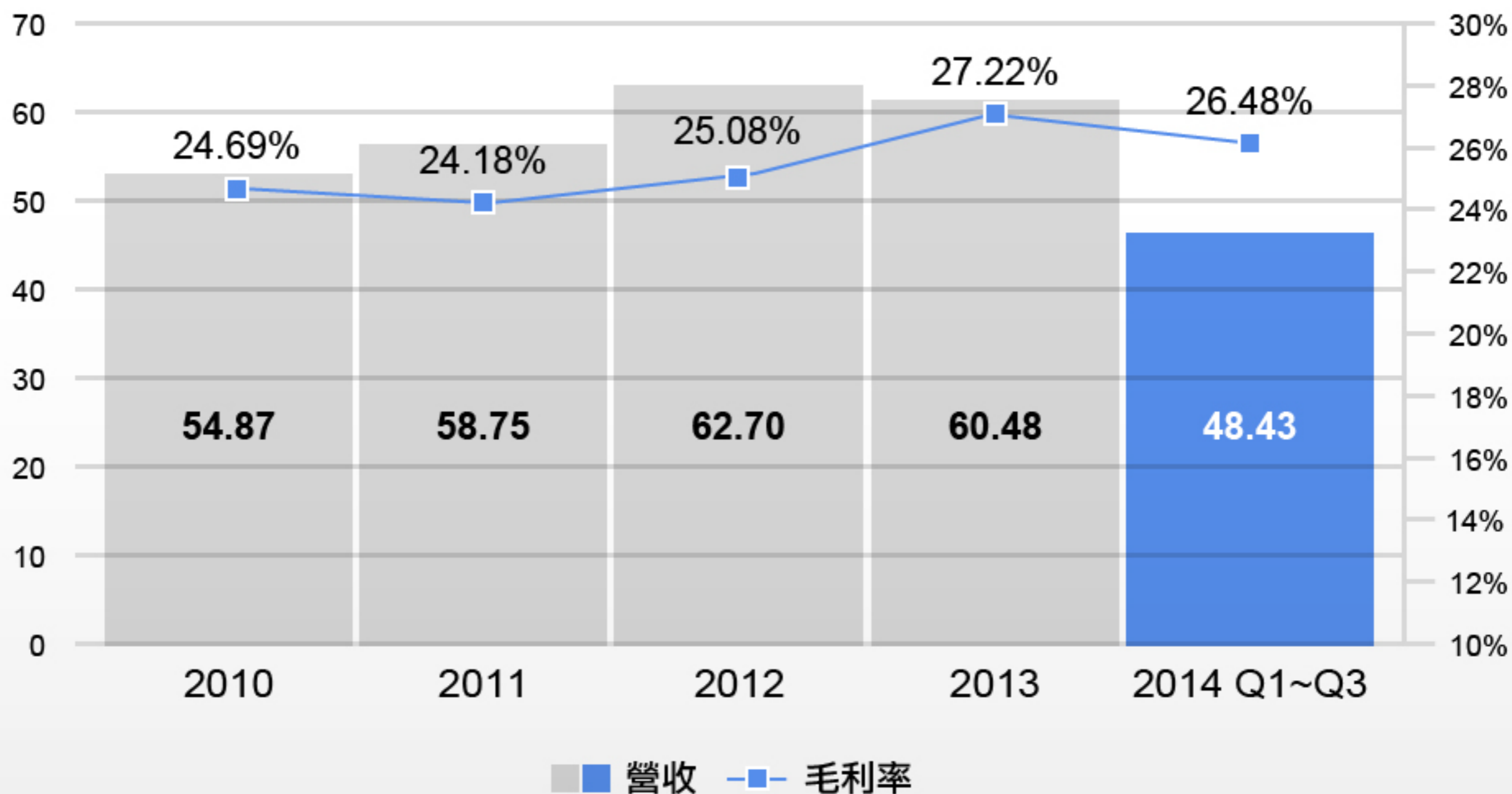

註：2010、2011 ROC GAPP；2012~2014 IFRS。

拓凱集團 稅後每股盈餘

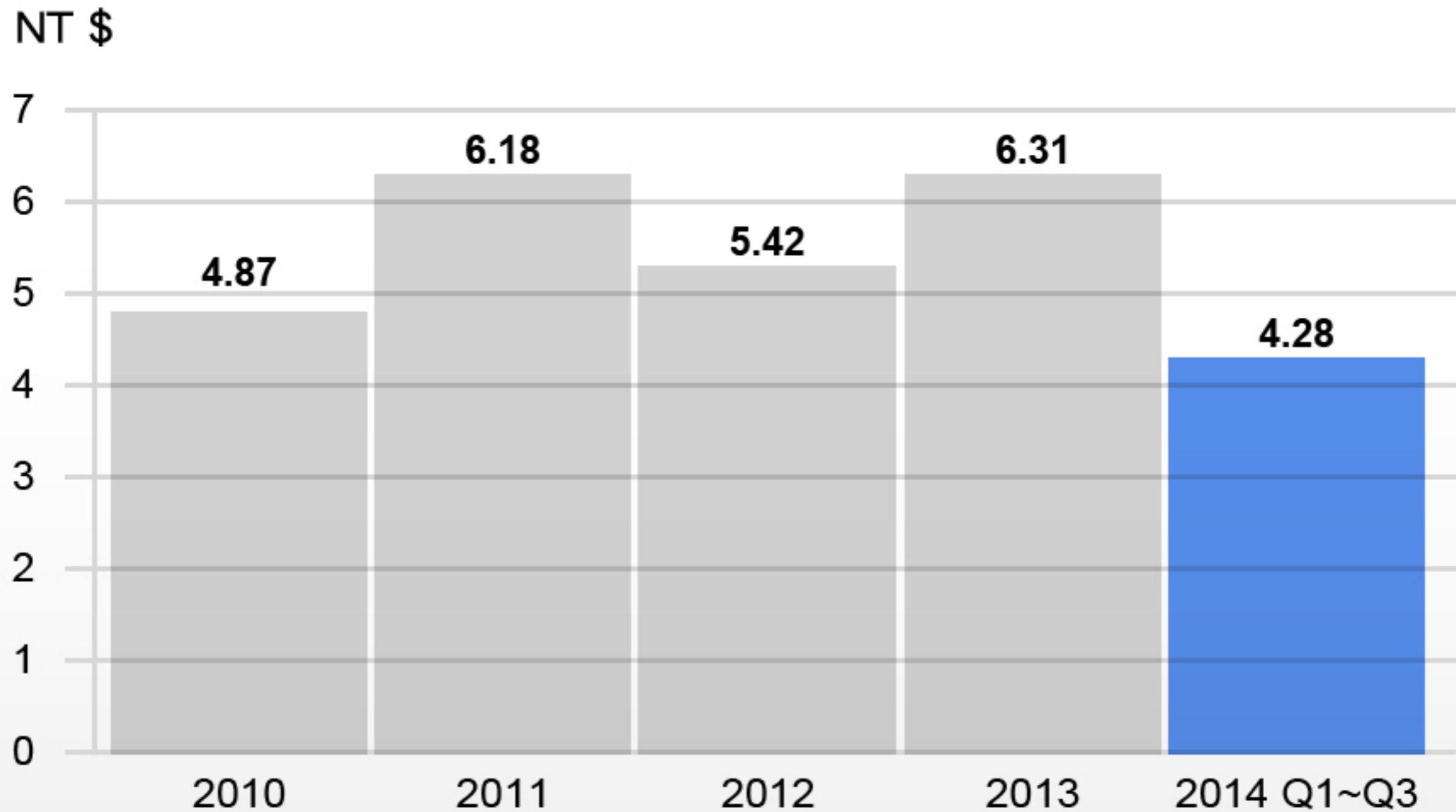

註：2010、2011 ROC GAPP；2012~2014 IFRS。

- 拓凱集團簡介
- 核心技術
- 拓凱事業群
- 企業社會責任

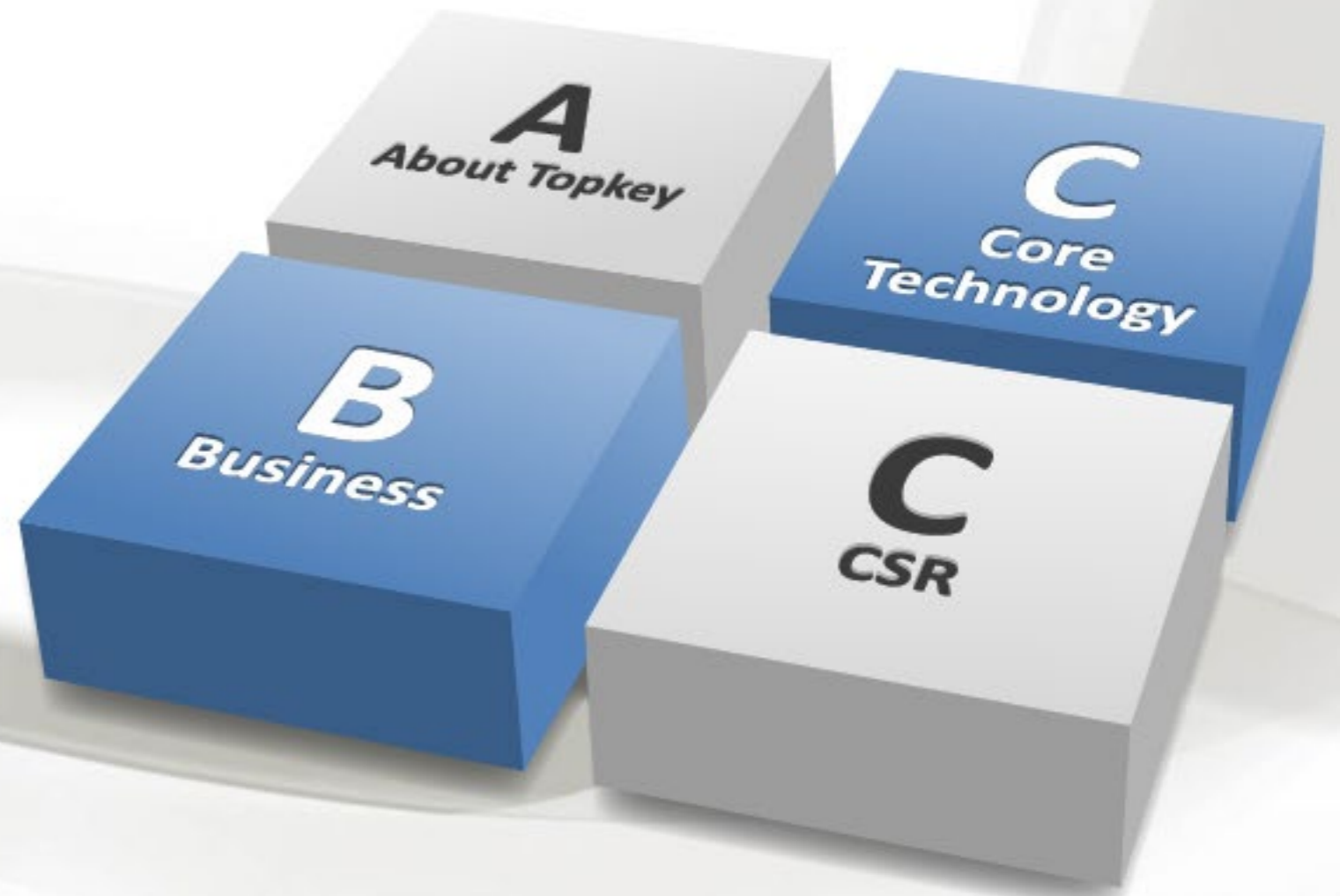

企業文化

致力成為客戶滿意、員工樂意、股東利益、
永續經營、回饋社會的五贏人本親善企業。



拓凱人文

員工是拓凱的重要資產：

拓凱致力以多元化活動與學習，全方位提升每一位夥伴的素質，並豐富其生命。

健康成長

定期舉行各類體育競賽與活動，藉由多元的社團參與，達到個人身心與工作家庭的完美平衡。



拓凱總共有31個社團，每年員工有超過七千人次參與各項社團活動。

拓凱人文

員工是拓凱的重要資產：

拓凱致力以多元化活動與學習，全方位提升每一位夥伴的素質，並豐富其生命。

快樂學習

推動多元化教育訓練課程與讀書會分享，讓組織文化生根，人員素養提升，落實全方位活力學習、樂在工作。



拓凱人文

員工是拓凱的重要資產：

拓凱致力以多元化活動與學習，全方位提升每一位夥伴的素質，並豐富其生命。

用心生活

豐富的生活與專業的成就，拓凱人獲得充分的照顧；

員工與眷屬更積極參與志工活動，關懷的觸角擴及社會。



企業社會責任

拓凱公司積極投入社會公益

2013年11月舉辦大臺中企業志工日

2012年12月舉辦大臺中企業志工日

2011年11月舉辦企業社會責任論壇

2011年3月日本震災，公司捐贈新台幣1,000萬元

2010年捐贈成立財團法人拓凱教育基金會

2009年關懷88莫拉克水災，公司捐贈台幣1,000萬元

2008年3月中國華東地區雪災，公司捐贈人民幣30萬元

2008年5月中國四川521地震，公司捐贈人民幣80萬元

2007年12月舉辦公司志工博覽會，號召全員投入志工行列



拓凱教育基金會
Topkey Foundation



感謝您

欲了解更多信息，請訪問本公司網站：

<http://www.topkey.com.tw>